

Howard B. Mattlin Middle School

Welcome Parents! Incoming Grade 7 Parent Transition Meeting

March 5, 2018

Joseph Coladonato, Ed.D., Principal
Regina Talento, Ed.D., Assistant Principal
Ms. Stephanie Ralton, Guidance Counselor
Mrs. Lenore Shalom, R.N.

A tradition of P.R.I.D.E

6th to 7th Grade Transition Student Perspective

Ari Kalinsky
Ava Mindich
Jordan Kenny



Overview of 7th Grade Courses

Teaming in Grade 7

- Students are on a team of teachers in grade 7 in all four core subject areas: Math 7-2 or Math 7-1 Social Studies, Science, and ELA
- World Language (Chinese, French or Spanish- Depending on course selection in grade 6)

Special Area Subjects:

- Technology, Family & Consumer Science, Music Studio & Art (Every Other Day – Semester)
- Physical Education & Health (Every Other Day - Full Year)

Optional Acceleration for 7th Grade

Math Courses

Mathematics 7 Accelerated

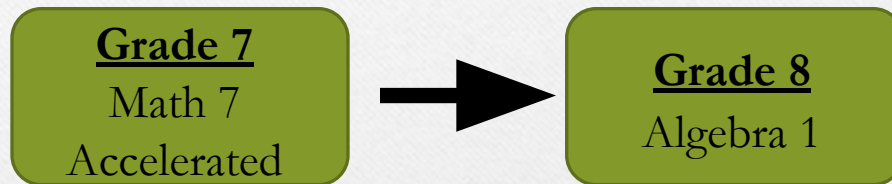

Mathematics 7

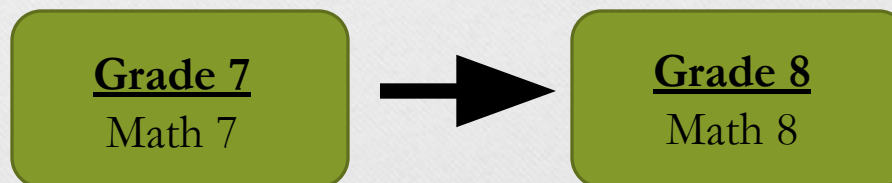

Mathematics

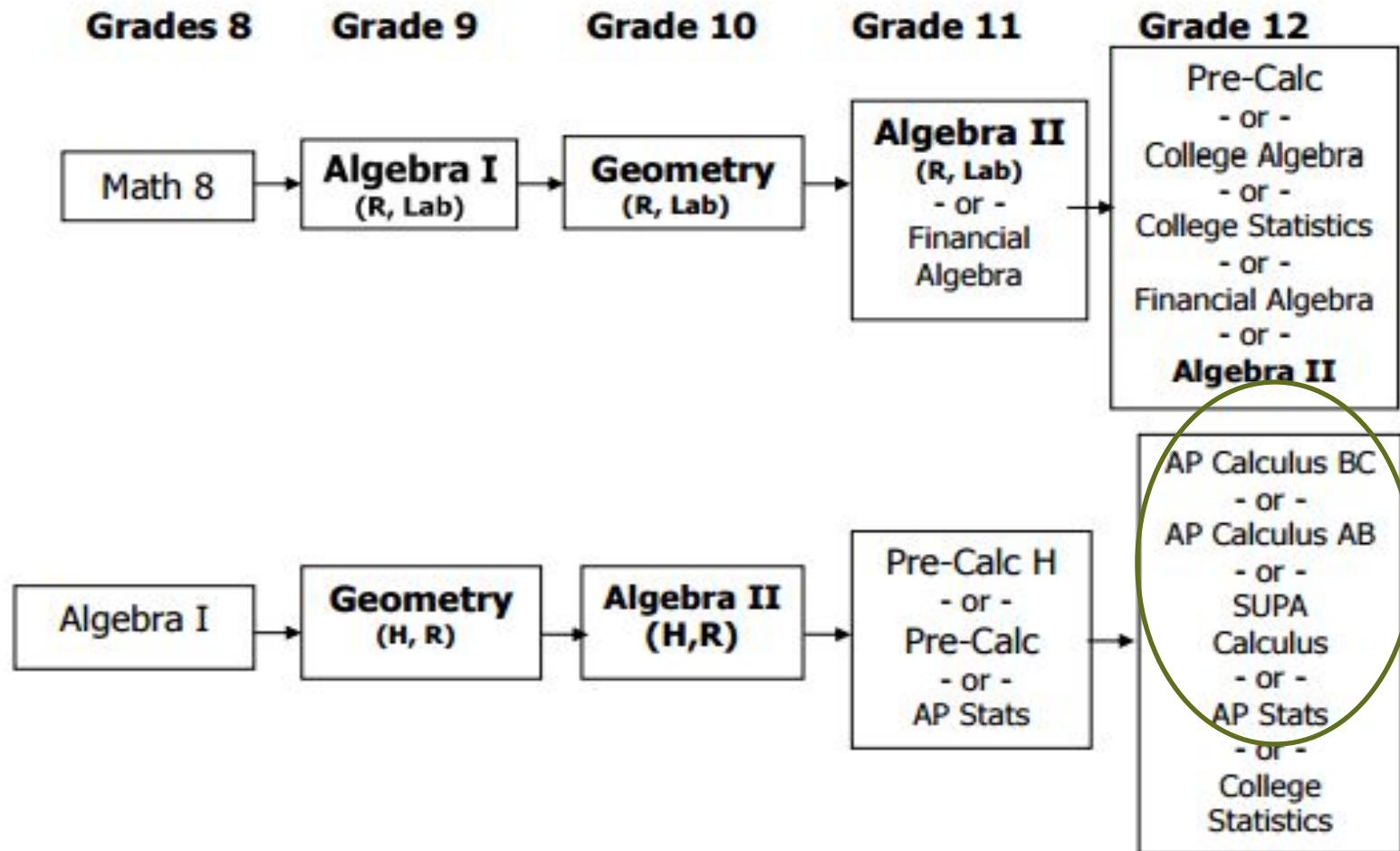

How will I know the recommendations for my child?

Course Verification Forms

- All parents/guardians will receive printed course verification forms in the mail on or about **March 19, 2018**
- Forms must be signed and returned to the Guidance Office at Mattlin Middle School by **March 30, 2018**
- Parents have the opportunity to discuss the recommendation with the teacher and guidance counselor

Course Verification Form

Grade 7

Required Courses:

702 Art 7

712 English

704 Family & Consumer Science

701 Music Studio

706 Lunch

722 Math 7 Accelerated

705 Phys. Ed.

740 Science

730 Soc. Studies 7

750 Spanish

766 String Orchestra

703 Technology

743 Health

What is Self-Selection?

- Opportunity to enroll in the accelerated course when not recommended
 - ✓ Conversation with the student
 - ✓ Conversation with teacher and guidance counselor
- What is the process for self-selection?
 - ✓ Complete and return a Self-Selection form for the accelerated course to guidance
 - ✓ Form must be returned by April 13, 2018



Excellence in Education

HOWARD B. MATTLIN MIDDLE SCHOOL
SELF-SELECTION FORM
2016-2017



Mattlin PRIDE

Student's First Name

Student's Last Name

Grade in 2015-2016

I would like to self-select my child into the accelerated course circled below. I realize that this was not the recommended course for my child for the upcoming school year. I am also aware that if my child does not perform well in this course and needs a change in placement during the school year, this could significantly impact his/her schedule.

Accelerated Course Offerings – Grade 7

722 Math 7 Accelerated

Accelerated Course Offerings – Grade 8

301 Algebra 1

403-1 Earth Science + Lab

801/903 Studio Art

Parent's Signature

Date

Student's Signature

This form must be returned to the guidance office
no later than Friday, April 1, 2016.

Academic Intervention Services (AIS)

- ✓ AIS Reading and/or Math
- ✓ Support is provided for all students that do not meet NYS Standards in the areas of Math and ELA
- ✓ Students will be recommended for AIS based on Multiple measures (classroom grades, NYS Scores, SRI, etc.)
- ✓ Traditionally taken in lieu of a special

Interscholastic Sports: Grades 7&8

- ✓ Various middle school sport teams throughout Long Island, each representing a particular school and sport
- ✓ Your child and his/her team will have a chance to represent the POB school district

Why Join a Team?

Promotes the physical, social, emotional, and psychological well-being of students

- ✓ Relieves stress
- ✓ Promotes exercise
- ✓ Improves athletic proficiency
- ✓ Encourages discipline, concentration, focus, and time management
- ✓ A shared team experience
- ✓ Socialization
- ✓ Raises self esteem
- ✓ Leads to positive academic achievement

Sports Schedules – Four Seasons

Fall Season

Sept. – Nov.

- ✓ Football
- ✓ Boys' Soccer
- ✓ Boys' Tennis
- ✓ Girls' Swimming
- ✓ Girls' Soccer
- ✓ Cheerleading
- ✓ Coed Cross Country

Winter 1 Season

Nov. – Jan.

- ✓ Boys' Basketball
- ✓ Boys' Swimming
- ✓ Girls' Volleyball
- ✓ Cheerleading

Sports Schedules

Winter 2 Season

Jan. - March

- ✓ Boys' Volleyball
- ✓ Girls' Volleyball
- ✓ Wrestling
- ✓ Coed Bowling

Spring Season

March - June

- ✓ Boys' Track
- ✓ Boys' Lacrosse
- ✓ Baseball
- ✓ Girls' Track
- ✓ Girls' Lacrosse
- ✓ Girls' Tennis
- ✓ Softball

Sports Routine

- ✓ Daily practices and/or games
- ✓ Starts at the end of the school day at 3:35 PM. Students are prohibited from leaving school after 2:50 PM dismissal due to safety concerns.
- ✓ Practice - transportation to location and parental pick up required
- ✓ Games - travel to location and return on bus with team

Obtaining Sports Registration Forms

- ✓ Go to POB website
- ✓ Departments
- ✓ Athletics – click on forms
- ✓ <http://www.pob.k12.ny.us/Page/3409>
- ✓ Print first 3 links

Interscholastic Participation Contract & Health History

Must be signed by parent and student

- **POB Concussion Information Sheet**
 - ❖ Must be signed by parent and student
- **POB Athletic Physical Form**
 - ❖ Must be completed by physician
 - ❖ Valid for one year from date signed
 - ❖ Fulfills 7th grade requirement for physical exam

Sports Registration Procedure

- ✓ Announcement 2 weeks before season starts
- ✓ Completed forms to be brought to health office by announced deadline(Interscholastic Participation, Physical Exam, Health History Update, Concussion)
- ✓ Nurse will sign Interscholastic Participation Contract
- ✓ Student to bring Interscholastic Contract and Concussion Form to Coach on 1st practice.

Points to Remember

- ✓ Each sport requires a new form.
- ✓ Medication not used during school hours requires physician's order and medication to be given to the coach (i.e., inhalers, epi pens, over the counter)
- ✓ If student absent or leaves school before end of the day, he/she may not participate in sports
- ✓ Medical excuses and/or clearance can only be given by physician

Clubs and Activities

- ✓ Middle School students continue to develop interests in clubs, student council, activities, music, and drama
 - Wide range of clubs that meet Zero Period on Monday and Wednesday.
- ✓ Become empowered to join Student Council

Music Program

✓ Students can participate in the following performing groups in grade 7:

- Symphonic Orchestra
- Chorus
- Band
- Jazz Band



	MONDAY	TUESDAY	WEDNESDAY	THURSDAY	FRIDAY
Zero Period Bell Schedule 7:49-8:30 Bus Arrives 7:40	Clubs	Music Performing Groups: Orchestra 6,7,8 Band 6,7,8 Chorus 7,8	Clubs	Music Performing Groups: Orchestra 6,7,8 Band 6,7,8 Chorus 7,8	Music Performing Groups: Orchestra 6,7,8 Band 7,8 Chorus 7,8
9th Period Bell Schedule 2:54-3:35 Bus Departure 3:45 (Approx)	Remedial Music Performing Groups: Chorus 5,6 Orchestra 5 Band 5	Remedial	Music Performing Groups: Chorus 5,6 Orchestra 5 Band 5	Remedial	Music Performing Groups: Chorus 5,6

Support in Grade Seven

- Academic changes
 - Increased workload
 - Challenging secondary level content
 - Fewer opportunities for parents to assist with more complex subject content
 - More opportunities for children to gain responsibility
 - Organization is critical

Social and Emotional Development

- A developmental year with many transitions.
 - Chronological vs. Developmental
 - Becoming more self aware
- Important to communicate with your child as peer groups become an important outlet.
- Reinforce that support in school becomes a vital resource
- The relationship between home and school is critical
- Higher expectations and increased student responsibility.
 - Important to arrive at school by 8:30 AM
 - Make use of Remedial Period (9th per. Mon, Tues, and Thurs.
 - Reinforce proper use of technology, social media, and Chromebooks (1:1 Devices) with regard to Go Guardian

Characteristics of Young Adolescents

- Rebellious
- Loyal to friends
- Need frequent affirmation
- Moody, restless, self-conscious
- Sensitive
- Mature at varying rates
- Seek acceptance
- Eager
- Passionate
- Caring
- Enthusiastic
- Smart
- Healthy risk taker
- Fearless

6th grade School Climate

What we are seeing



- Maturation
 - Empathetic
 - Decision making
 - Ownership
 - Trustworthy
 - Advocating for oneself and others
- Our kids want to be involved in school
 - Our kids want to be involved in decisions
 - Our kids want to help younger students
 - Want to be responsible
 - Leaving a legacy

Down The Mattlin Road

- **Decision-Making Against Destructive Behaviors Presentations**
- **6th-7th- Grade Transition Assemblies**
- **6th Grade Workshops**



Question and Answer Session



Thank you to all of our parents
for joining us this evening



Mattlin Middle School
A tradition of P.R.I.D.E